

Design and Fabrication of a Prototype Electric Vehicle

Arun Kumar Maurya

Department of Electrical and Electronics Engineering, Ajay Kumar Garg Engineering College,
27 Kmstone, NH-24, Adhyatik Nagar, Ghaziabad 201009 UP India
arun1621095@akgec.ac.in

Abstract – Due to the increase in the cost of fuels and pollution, alternative to conventional internal combustion engine powered vehicles is needed. As electric vehicles are environment friendly, they are considered green transportation. In an electric vehicle various components like motor, battery, controllers are used. While designing an electric vehicle, the first and foremost component to be selected is an electric motor which replaces the Internal Combustion engines of conventional vehicles. Therefore, electric motor used in an electric vehicle must produce appropriate power and other characteristics that are required for traction purpose. The important task is to select an appropriate rating of motor based on the load to be carried. This paper describes the procedure for proper selection of rating of electric motor with an example of DC motor for an electric car. Vehicle dynamics is considered for selecting the proper electric motor that would provide required power and torque for traction. To achieve all traction characteristics in compact size, a proper selection of motor rating should be done based on the load.

Keywords: Electric motor, Electric car, Selection of rating of motor, Electric vehicle, DC motor

I. INTRODUCTION

ELECTRIC vehicle is one of the best future technologies for reducing the use of fossil fuels and also to act as environmental friendly by reducing the emission of harmful gases. The electric vehicle has many components like charging module, converters, controllers, batteries and electric motor. Block diagram of power flow in an electric vehicle is shown in Fig.1.

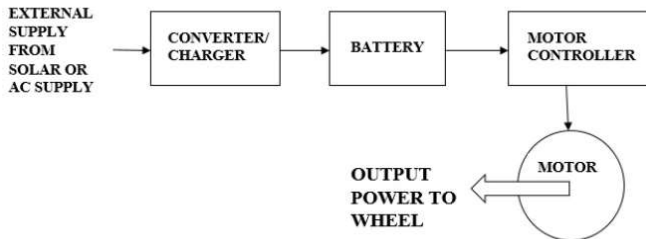

Figure 1. Block diagram of power flow in an electric vehicle.

Power supply can be obtained externally by using solar panels to generate electricity or from domestic AC supply. This power is then rectified using converter and is made available to the

battery through charging module. The battery supplies electric power to the motor through a motor controller, which helps in controlling the input and output parameters of the motor. The output mechanical power from the motor is given to the wheel through a drive shaft. In this way, electric power flows through various components in an electric vehicle and gets converted into mechanical power. Therefore, it is clear that an electric motor determines the output characteristics of vehicle as a whole in terms of power, torque, speed, etc. The electric motor selected for driving a vehicle must have the ability to provide sufficient power and torque to overcome the force due to load and other opposing forces acting on the vehicle. In this paper, section II deals on calculating the power rating required to drive an electric vehicle, section III explains about the different types of motors used for traction purpose, section IV presents the simulation result of DC motor for an electric car being illustrated in this paper.

II. POWER RATING BASED ON VEHICLE DYNAMICS

For deciding the power rating of a vehicle, the vehicle dynamics like rolling resistance, gradient resistance, aerodynamic drag are considered. For illustration, procedure for selecting motor rating for an electric car of gross weight 5 kg is considered. The force required for driving a vehicle is calculated as

$$F_{total} = F_{rolling} + F_{gradient} + F_{aerodynamic\ drag} \quad (1)$$

F_{total} is the total tractive force that the output of motor must overcome, in order to move the vehicle.

Rolling resistance: Rolling resistance is the resistance offered to the vehicle due to the contact of tires with road. The formula for calculating force due to rolling resistance is given by

$$F_{rolling} = C_{rr} M g \quad (2)$$

where,

C_{rr} = coefficient of rolling resistance

M = mass in kg,

g = acceleration due to gravity = 9.81 m/s²

For the application considered, $C_{rr}=0.01$, $M = 5$ kg. So that

$$F_{\text{rolling}} = 0.49 \text{ N}$$

Power required to overcome the rolling resistance of 0.49 N is:

$$P_{\text{rolling}} = F_{\text{rolling}}(v/3600) = 0.49 \cdot 1.8/3600 = 0.245 \text{ W} \quad (3)$$

where v = velocity in kmph.

B. GRADIENT RESISTANCE

Gradient resistance of the vehicle is the resistance offered to the vehicle while climbing a hill or flyover or while travelling in a downward slope. The angle between the ground and slope of the path is represented as α , as shown in Fig.2.

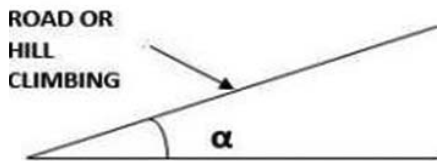

Figure 2. Angle between the ground and slope of a path.

Gradient resistance is given by

$$F_{\text{gradient}} = Mg \cdot \sin\alpha \quad (4)$$

In this illustration, let us consider the electric car runs on a flat road. Therefore, angle $\alpha = 0^\circ$

$$F_{\text{gradient}} = 0 \text{ N.} \quad (5)$$

So, the power required to overcome gradient resistance is also zero.

So, the power required to overcome gradient resistance is also zero.

Aerodynamic drag: Aerodynamic drag is the resistive force offered due to viscous force acting on the vehicle. It is largely determined by the shape of the vehicle. The formula for calculating the aerodynamic drag is given by

$$F_{\text{aerodynamic drag}} = 0.5CA A_f \rho (V + V_0)^2 \quad (6)$$

These are the three main forces which act on the vehicle when it travels at constant speed. While accelerating and decelerating the effect of force due to inertia also acts. In this illustration, let us consider the power required to overcome aerodynamic drag and other resistive forces to be around 1.81 W.

Therefore, the total tractive power required to move the vehicle is

$$P_{\text{total}} = 0.245 \text{ W} + 1.81 \text{ W} = 2.055 \text{ W} \quad (7)$$

Additionally, losses due transmission of power are to be included. Therefore, the mechanical power output (M_{tractive}) required to drive the vehicle is given by

$$M_{\text{tractive}} = P_{\text{total}} / \eta \quad (8)$$

where, η = efficiency of the transmission gear system.

Let us consider the efficiency of the transmission system to be 0.85. Therefore the mechanical power output required is:

$$M_{\text{tractive}} = P_{\text{total}} / \eta = 2.055 / 0.85 = 2.41 \approx 3 \text{ W}$$

For the illustration of selection of power rating for an electric car of 5 kg, a motor with output power rating of 3W has to be selected. In this way, power rating required to drive an electric vehicle of particular load is calculated.

III. TYPES OF ELECTRIC MOTORS USED IN ELECTRIC VEHICLES

The power required for the traction is delivered by the electric motor in an electric vehicle which is of different types. Therefore, selecting an appropriate motor is also important. Various types of electric motors used in electric vehicles are:

DC series motor: A DC motor is one in which the field winding is connected in series to the armature winding [2]. Therefore it is a self-excited DC motor. It has brushes and has mechanical commutation

The advantage of DC series motor is that it produces high starting torque [3]. During this condition the motor draws less current and power. DC series motor is widely used in traction because the torque produced is directly proportional to the square of the current ($T \propto I^2$) [4]. The disadvantage is that the speed regulation is poor and the motor should be loaded before starting. It has a periodic commutation. The lifetime is short. The electric noise is high. The speed-torque characteristic is moderately flat.

Three Phase Induction Motor: Induction motor is based on the principle of electromagnetic induction in which the conductors in the changing magnetic field induce an emf across the conductor [4]. Due to the interaction of stator and rotor flux, the motor rotates. The advantages of induction motor are simple in construction and are cheaper and maintenance-less [4]. And they can be operated in dirty environments like dust, presence of water and explosive areas due to the absence of brushes which will produce sparks. They are self-starting motors. The disadvantage is that the speed control is difficult. The motor operates under lagging power factor hence some power factor correcting devices are required. They have higher copper loss.

Permanent Magnet Motors:

Permanent magnet motor is a synchronous motor in which the rotor rotates at the same speed as the stator. It differs from conventional motor in construction where the field winding of the rotor is replaced by permanent magnet. The permanent magnet synchronous motor is also called as PMAC (Permanent Magnet AC motor), when the emf induced is of sinusoidal shape. They have high efficiency and higher torque density. The permanent magnet DC motor or Brushless DC motor is powered by DC supply and it has electronic commutation instead of mechanical commutation [5]. They are used in toy industries, computer drives, automobiles. The advantages are they are smaller in size. They have no field windings hence the losses are less and efficiency is high [5]. The only disadvantage is that it is costlier than DC series and AC induction motors [5]. Any motor from above mentioned types can be selected for traction purpose. The best choice is Brushless DC motor, as it has better characteristics required for traction when compared to DC series and AC Induction motor.

IV. SIMULATION RESULT OF DC MOTOR FOR AN ELECTRIC CAR

A DC motor is selected as the traction motor for an electric car of load 5 kg. The excitation voltage is selected as 12 V for the DC motor. For a 12 V, 3 W DC motor the simulation results of Road speed values can be assumed depending on road characteristics. If speed values are assumed then the torque values can be calculated if the wheel dimensions are available. The road load values encountered by the vehicle values are known. The total road load is the sum of the Rolling Resistance, Gradient Resistance and Aerodynamic Drag which are known or already calculated in above sections.

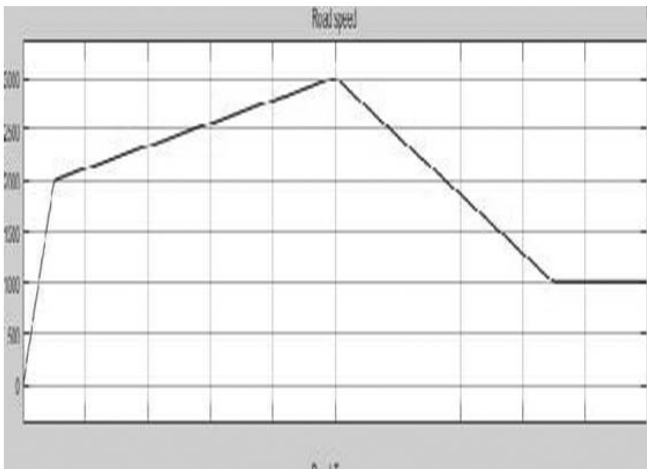

Figure 3. Speed characteristics.

Speedvalues= [0 0.1 0.3 0.5 0.7 0.9 1.1 1.3 1.5 1.7 1.9]
 Speed time = [0 1 34 5 6 7 8 9 10]
 Torque values = [0 1 2 3 4 -3 -2 -10]
 Torque time = [0 1 2 3 4 5 6 7 8 9 10]

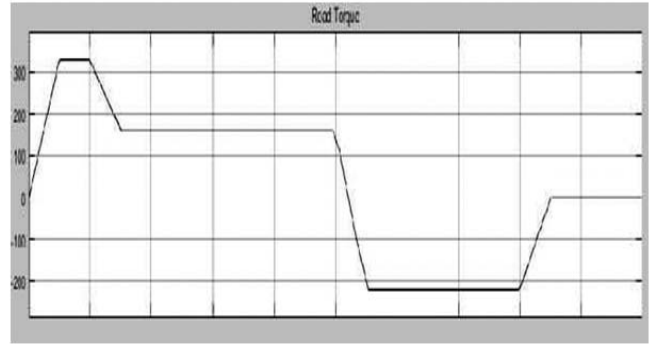

Figure 4. Torque characteristics.

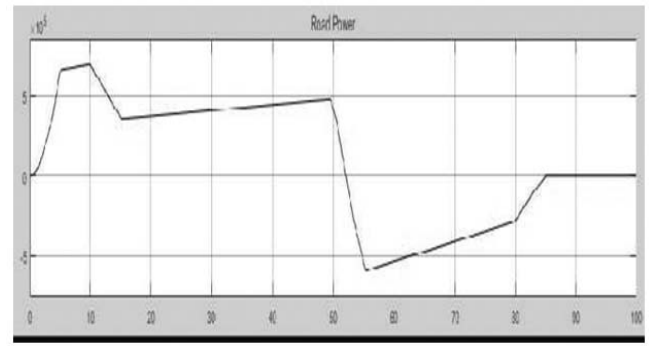
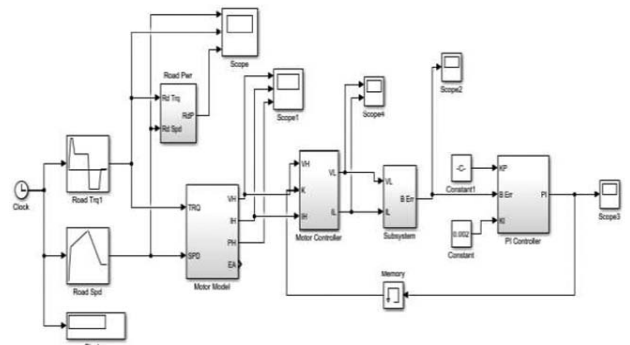

Figure 5. Power characteristics.



SIMULINK MODEL OF ELECTRIC VEHICLE

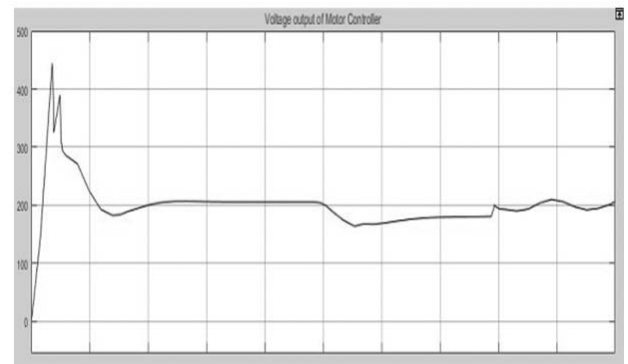

Figure 6. Voltage output of motor controller.

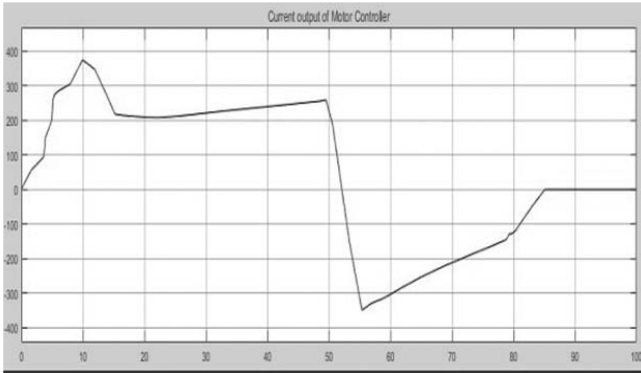

Figure 7. Current output of motor controller.

When both current and voltage are positive values then the DC Motor is providing torque in the direction of rotation and power is being transferred to the load.



Figure 8. Battery voltage error.

The simulation model adjusts the controller gain (K) to meet drive torque. The minimum value of gain(K) is 0.4 and maximum value is 2.8.



Figure 9: PI controller K value.

V. ENVIRONMENTAL IMPACT

Due to higher efficiency of electric engines as compared to

combustion engines, even when the electricity used to charge electric vehicles comes from a CO₂-emitting source, such as a coal- or gas-fired powered plant, the net CO₂ production from an electric car is typically one-half to one-third of that from a comparable combustion vehicle. Electric vehicles release almost no air pollutants. In addition, it is generally easier to build pollution-control systems into centralized power stations than retrofit enormous numbers of cars. Electric vehicles typically have less noise pollution than an internal combustion engine vehicle, whether it is at rest or in motion.

Electric vehicles emit no tailpipe CO₂ or pollutants such as NOx, NMHC, CO and PM at the point of use. Electric motors don't require oxygen, unlike internal combustion engines; this is useful for submarines. While electric and hybrid cars have reduced tailpipe carbon emissions, the energy they consume is sometimes produced by means that have environmental impacts.

For example, the majority of electricity produced in the United States comes from fossil fuels (coal and natural gas), so use of an electric vehicle in the United States would not be completely carbon-neutral. Electric and hybrid cars can help decrease energy use and pollution, with local no pollution at all being generated by electric vehicles, and may someday use only renewable resources, but the choice that would have the lowest negative environmental impact would be a lifestyle change in favour of walking, biking, use of public transit or telecommuting. Governments may invest in research and development of electric cars with the intention of reducing the impact on the environment, where they could instead develop pedestrian-friendly communities or electric mass-transit.

VI. CONCLUSION

Based on the calculations done in section II, a 3W , 12V DC motor is selected and designed for driving a 5 kg electric car. Apart from required output power rating, the simulation output result shows that the speed, torque parameters obtained also meet the necessary characteristics that are required for driving an electric car. This simulation helps to determine the energy flow and performance of the drive and can be used for electric vehicle applications. The procedure for selection of power rating of an electric motor and proper selection of motor is explained.

REFERENCES

- [1] Prasun Mishra, SumanSaha and H.P. Ikkurti, "A methodology for selection of optimum power rating of propulsion motor of three wheeled electric vehicle on Indian drive cycle", *International Journal on Theoretical and Applied Research in Mechanical Engineering*, vol. 2, no.1, p. 96, 2013.
- [2]. Sagar Tatipamula, "Study of parallel electric hybrid three-wheeled motor taxi", *Proc. International conference on Green Computing and Technology 2013*, in *International Journal of Computer Applications* (0975-8887), pp. 38-39.

- [3]. Bekheira Tabbache, Soane Djebarri, Abdelaziz Kheloui and Mohamed Benbouzid, "A power presizing methodology for electric vehicle traction motor", *International Review on Modelling and Simulations*, October 2013.
- [4]. Amir Ahmed and Dikki D. Bhutia, "Propulsion System Design and Sizing of an Electric Vehicle", *International Journal of Electronics and Electrical Engineering*, vol. 3, no. 1, February 2015.
- [5]. Y. Mastanamma and M Aruna Bharathi, "Electric Vehicle Mathematical Modelling and Simulation Using MATLAB-Simulink" *IOSR Journal of electrical and electronics engineering*, vol. 12, no. 4, pp.47-53, Jul. – Aug. 2017.
- [6]. J. J. Eckert, L. C. A. Silva, E. S. Costa, F. M. Santiciolli, F. G. Dedini and F. C. Corrêa, "Electric vehicle drive train optimisation," *IET Electrical Systems in Transportation*, vol. 7, no. 1, pp. 32- 40, 2017.
- [7]. Y. Wang, E. Lü, H.Lu, N. Zhang and X. Zhou, "Comprehensive design and optimization of an electric vehicle power-train equipped with a two-speed dual-clutch transmission" *Advances in Mechanical Engineering*, vol. 9, no.1, pp 1-13, 2017.
- [8]. M. W. Salehen, P. Su'ait, H. Mohd Razali and Sopian, Kamaruzzaman, "Battery management systems (BMS) optimization for electric vehicles (EVs) in Malaysia", *Proc. AIP Conference*, pp. 1-7, 2017.



Arun Kumar Maurya is student in Department of Electrical and Electronics Engineering, Ajay Kumar Garg Engineering College (2016-2020 Batch). He is silver medalist in B.Tech course. He is involved in projects in AKGEC like Smart India Hackathon, KPIT Sparkle etc. and participated in technical and non-technical events at zonal, university, national and international levels.

Published research papers on 'An evolutionary optimization based fuzzy-PID controller design' and 'Study of thermal decomposition of polystyrene using viscometric analysis and assessment of its reaction rate models'. His interest areas include power systems, signals and systems, polymer synthesis and electrical machines and control system.